

DREHMO[®] i - Matic Electrical actuator with integral controls

Supplementary operating manual for actuators with MODBUS interface

MODBUS

Modbus redundant interface electronic
built in the electronic housing

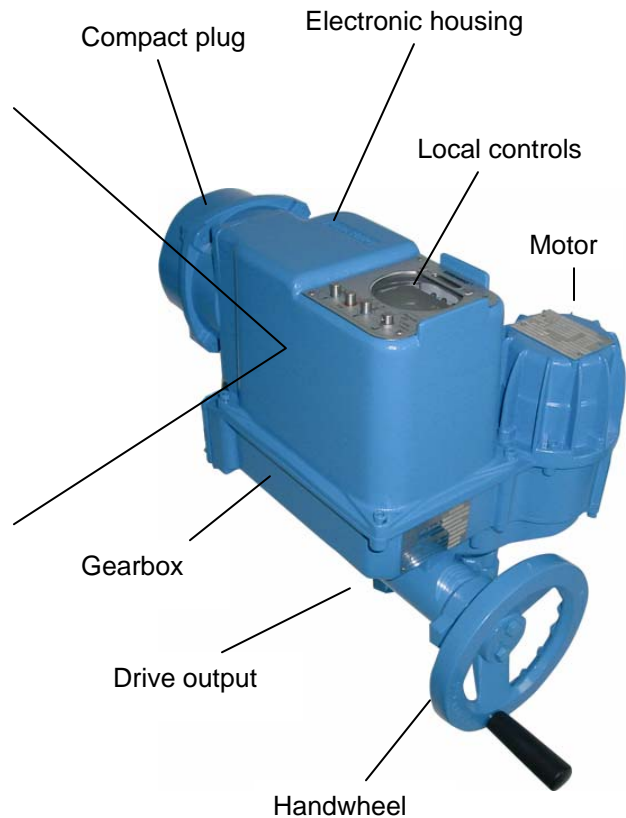

Installation Manual
Operating Manual

part number: 166 671
Version 03
Date: Oct. 18th, 2006

INFORMATION

This installation manual should only be used in conjunction with the operating manual for drives!

This manual must be kept for future use.

Table of contents

1	<u>Introduction</u>	3
2	<u>Interface technology</u>	3
2.1	Physical interface	3
2.2	Supported function codes	4
2.3	Data model	4
2.3.1	Accesses for master input data (actuator feedback signals)	5
2.3.2	Accesses for master output data (actuator command signals)	8
2.4	Parameterisation	10
2.4.1	Communication settings – addresses, baud rate, parity	10
2.4.2	Number of channels – bus profile	10
2.4.3	Redundancy modes – line redundant vs. master redundant	10
2.4.4	Function Fail-Safe – Timeout setting	10
2.4.5	Fault messages	11
2.5	Electrical connection	12
2.5.1	Actuators i-Matic for normal operation – DiM-X0X	12
2.5.1.1	Compact plug assembly	12
2.5.1.2	Bus termination	14
2.5.1.3	Grounding of the cables´ shields in case of copper cable use	14
2.5.1.4	Interface with fibre optic connection	15
2.5.2	Actuator i-Matic for Ex-Zone acc. ATEX device category 2 G – DiM-X1X	16
2.5.2.1	Connection with copper cable	16
2.5.2.2	Connection with fibre optic cable	17
2.5.2.2.1	Setting of transmission power	17
2.6	Interface to external sensor - process inputs	18

1 Introduction

This document describes the expansion of modbus RTU functionality for i-Matic actuator.

2 Interface technology

2.1 Physical interface

The physical interface is in accordance to the MODBUS over Serial Line Specification & Implementation guide that can be found on the following web site: <http://www.modbus.org/>

The physical interfaces uses 2-wire RS485.

The following parameters are possible for the communication configuration:

Baud rates:

38400 bit/s
19200 bit/s
9600 bit/s
4800bit/s
2400bit/s
1200bit/s
600bit/s
300bit/s

The parity can be configured as follows:

parity none, with two stop bits,
parity even, with one stop bit,
parity odd, with one stop bit

The interface card has two separate 2-wire RS485 modbus channels. The baud rate and parity settings are common for both channels. Each of the channels can be assigned an individual slave address in the range of 1 to 247 (different addresses are possible for test-purposes on a single master).



Broadcast messages are not supported.

In case of a redundant connection, the slave device decides itself about the channel priority. Only the commands of the high priority channel are executed. For maintenance reasons there is a feedback bit for the channel quality of each channel and a command bit to change the channel priority.

The physical connection is done on a separate interface board mounted in the compact plug. The shield of the cables have to be fixed on the according strain relieves on this interface board. For each channel there exists separate screw-terminals for the incoming and outgoing signals and a dipswitch for the optional termination of the lines. Furthermore there are dipswitches for the shield connection of incoming or outgoing cables to ground potential.

2.2 Supported function codes

Among the list of possible modbus functions as described in the modbus guidelines, the following function codes are supported:

FC 01	Read Coil Status	read single bit of master output data (command check)
FC 02	Read Input Status	read single bit as input to master (bit feedback)
FC 03	Read Holding Registers	read back of master output data as integer (command check)
FC 04	Read Input Registers	read data as input to master (word feedback)
FC 05	Force Single Coil	write single bit of master output data (command)
FC 06	Preset Single Register	write single data of master output data (command)
FC 15	Force Multiple Coils	write multiple bit of master output data (commands)
FC 16	Preset Multiple Registers	write multiple data of master output data (commands)
FC 17	Report Slave ID	Read TAG/KKS

2.3 Data model

The discrete single bit command and status bits for the actuator are mapped in a linear addressable structure. Each command or status bit can be accessed individually. The commands are also addressable as single or multiple words.

The reserved addresses for input and output data are as follows:

Coil addresses: range 1 (Hex 0x01 to 512 (Hex 0x200) results in 512 coils reserved

Register addresses: range 513 (Hex 0x201) to 544 (Hex 0x220) results in 32 registers reserved

2.3.1 Accesses for master input data (actuator feedback signals)

The following table gives detailed information about the addresses of the actuator feedback signals.

Register	Bit	Coil	Signal	Meaning
0x201	0..7	1..16	Position value Low-Byte	0...1000ppt actual position value
	8..15		Position value High-Byte	
0x202	0	17	General fault signal 1	General fault signal 1 is active
	1	18	General fault signal 2	General fault signal 2 is active
	2	19	Phase failure	One of the three phases has failed
	3	20	Failure internal 24 V DC	Only possible in case of external supply
	4	21	Failure externally supplied 24 V DC	Only possible in case of external supply
	5	22	Torque in OPEN direction	Max. torque in the OPEN direction exceeded
	6	23	Torque in CLOSED direction	Max. torque in the CLOSED direction exceeded
	7	24	Drive in fail-safe	Drive is in the fail-safe mode
	8	25	Drive moves to OPEN (only statically)	Movement in direction to OPEN position signal
	9	26	Drive moves to CLOSED (only statically)	Movement in direction to CLOSE position signal
	10	27	Drive in end of travel position OPEN	End of travel message only acc. to position
	11	28	Drive in end of travel position CLOSED	End of travel message only acc. to position
	12	29	Drive in end of travel position OPEN+Drehmo	End of travel message only if path and torque
	13	30	Drive in end of travel position CLOSED+TORQUE	End of travel message only if path and torque
	14	31	Motor too hot	Signal excess temperature motor
0x203	15	32	Drive in the remote mode	Display of the operating mode
	0	33	Drive in the local mode	Display of the operating mode
	1	34	Drive locally controlled	Drive is locally controlled
	2	35	Activation of discrete commands	A remote command OPEN or CLOSE can be given (Automatic mode = 0)
	3	36	Drive in the learn mode	Display of the operating mode
	4	37	Locking	Parameter setting for remote command
	5	38	Torque limit deactivation in OPEN	Parameter setting for deactivation
	6	39	Torque limit deactivation in CLOSED	Parameter setting for deactivation
	7	40	Start-up bridging in OPEN active	Parameter display
	8	41	Start-up bridging in CLOSED active	Parameter display
	9	42	Local_ind = NOT Remote	Drive is not in the remote mode
	10	43	Emergency travel active	Status indication
	11	44	Approach fail-safe position	Parameter display
	12	45	Pulse generator active	Parameter display
	13	46	Intermediate position 1	Message active between Z and ZS 1
14	47	Intermediate position 2	Message active between ZS 2 and OPEN	
15	48	Drive does not start	Warning message	

**Supplement operating manual for DREHMO i-Matic actuators with integrated
MODBUS fieldbus interface**

Register	Bit	Coil	Signal	Meaning
0x204	0	49	Torque warning OPEN	Torque higher than torque warning level set
	1	50	Torque warning CLOSED	Torque higher than torque warning level set
	2	51	No signal of reference value	If imxx5, message if no reference value
	3	52	Hardware fault	Warning message
	4	53	Combined sensor defective	Warning message
	5	54	system check error	During self-check the electronic unit has detected an error. The unit then performs a reset and tries to enter the state fail-safe. The indication can be cleared by using the acyclic bit „Reset system test error“ in slot 1 index 240, or by using the local reset in system>reset, or by a power off on cycle. The kind of error (refer to operating manual of <i>i-matic</i>) can be read out by using the acyclic service “system test error code” in slot 1 index 195 or the system entry under actual value diagnosis on the local control station. This indication is important for safety related systems, if due to an error the system needs to be brought to a safe state.
	6	55	Maintenance required	Perm. operating data are exceeded
	7	56	Actuator is served	Logged in user is specialist or manufacturer for service reasons
	8	57	Regulating time too long	Regulating time longer than max. running time
	9	58	Max. valve stroke exceeded	Regulating distance longer than stroke of valves
	10	59	Hand wheel operation	Actuators hand wheel is in usage
	11	60	Rotation monitor	Set if rotation direction is wrong
	12	61	Data exchange channel 1	Data exchange on channel 1 active
	13	62	Data exchange channel 2	Data exchange on channel 2 active
	14	63	Channel 1 primary	Channel 1 commands are in use due to highest channel priority
	15	64	Channel 2 primary	Channel 2 commands are in use due to highest channel priority
0x205	0..15	65..80	Torque value	0...1000ppt of the torque value at power output
0x206	0..7	81..96	Position value low byte	0...1000ppt of analogue input 1
	8..15		Position value high byte	
0x207	0..7	97..112	Position value low byte	0...1000ppt of analogue input 2
	8..15		Position value high byte	
0x208	0	113	Process input 1	State of digital input 1
	1	114	Process input 2	State of digital input 2
	2	115	Process input 3	State of digital input 3
	3	116	Process input 4	State of digital input 4
	4	117		
	5	118		
	6	119		
	7	120		
	8..15	121..128		
0x209.. 0x220		129..512		

In order to access the feedback signals, the function codes FC 05 (Force Single Coil) or FC 06 (Preset Single Register) have to be used. The following tables give telegram examples for these function codes.

Supplement operating manual for DREHMO i-Matic actuators with integrated MODBUS fieldbus interface

telegram example FC02 read 128 bit as input to master (128 bit feedback)

Request

C8	02	00	00	00	80	68	33
----	----	----	----	----	----	----	----

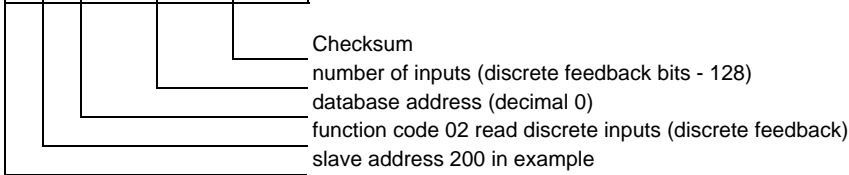

Response

C8	02	10	C4	03	0F	00	84	42	A0	50	00	00	00	00	00	00	00	00	1F	FD
----	----	----	----	----	----	----	----	----	----	----	----	----	----	----	----	----	----	----	----	----

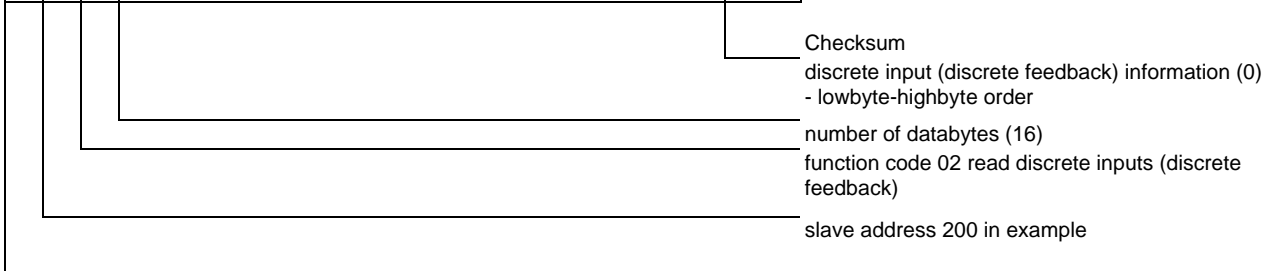

telegram example FC04 read data as input to master (word feedback)

Request

C8	04	02	00	00	08	E1	ED
----	----	----	----	----	----	----	----

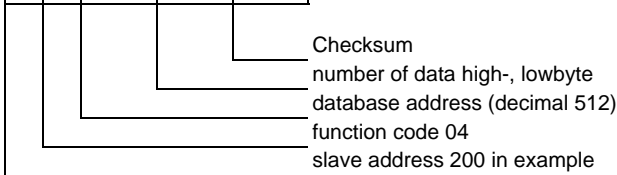

Response

C8	04	10	03	C4	00	0F	42	84	50	A0	00	00	00	00	00	00	00	00	99	41
----	----	----	----	----	----	----	----	----	----	----	----	----	----	----	----	----	----	----	----	----

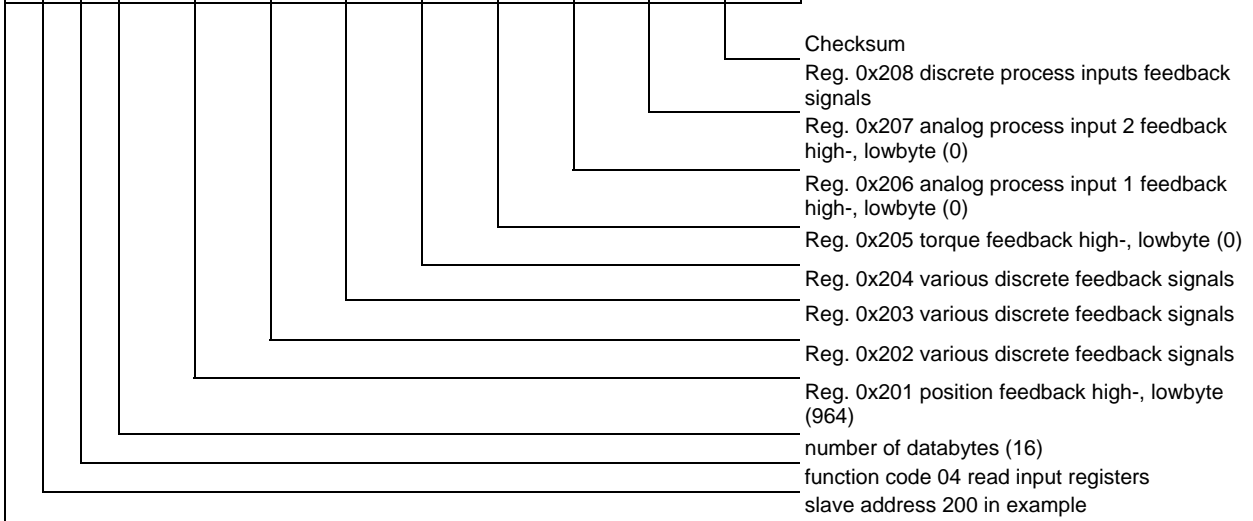

It is important to pay attention to the fact that the address count in the telegrams is starting at zero and the coil and register address counts are starting at one, thus resulting in an address offset of one!

2.3.2 Accesses for master output data (actuator command signals)

Register	Bit	Coil	Signal	Meaning
0x201	0..7	1..8	Reference value low byte	Reference value 0...1000 ppt
	8..15	9..16	Reference value high byte	
0x202	0	17	Automatic mode	Activates the integral 3-point position controller
	1	18	Stop	Stops the drive when automatic = 0
	2	19	Close	Moves the drive to CLOSED when automatic = 0
	3	20	Open	Moves the drive to OPEN when automatic = 0
	4	21	Emergency travel (ESD)	Activates the emergency travel of the drive
	5	22	Pulse operation active	Activates pulse operation when set to external
	6	23	Enable local control	Local control on station is enabled
	7	24	Channel select	Channel switch over on 0 to 1 transition
	8	25	Fault Acknowledge	Reset mechanism for dedicated stored faults (e.g. torque, phase errors) as described in actuator operation manual - valid for software revisions greater or equal V01.05.0048
0x203.. 0x220	9..15	26..32	unused	unused

In order to access the command signals, the function codes FC 05 (Force Single Coil) or FC 06 (Preset Single Register) are recommended to be used. The function codes FC 15 (Force Multiple Coils) and FC 16 (Preset Multiple Registers) are also supported. The following tables give telegram examples for FC05 and FC06 function codes.

telegram example FC05 write single bit of master output data (command OPEN)

Request

C8	05	00	13	FF	00	6C	66
----	----	----	----	----	----	----	----

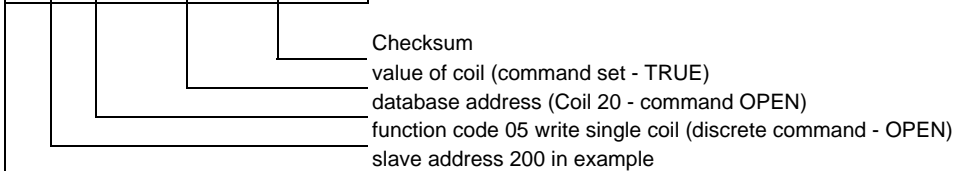

Response

C8	05	00	13	FF	00	6C	66
----	----	----	----	----	----	----	----

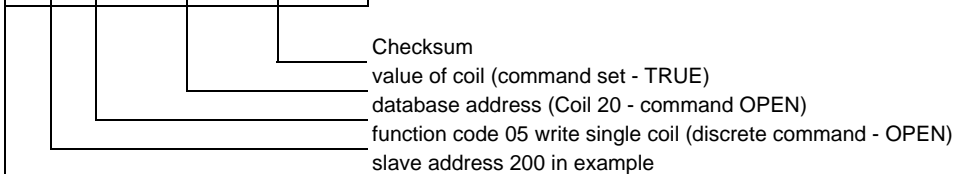

telegram example FC06 write single data of master output (setpoint value to 500)

Request

C8	06	02	00	01	F4	99	FC
----	----	----	----	----	----	----	----

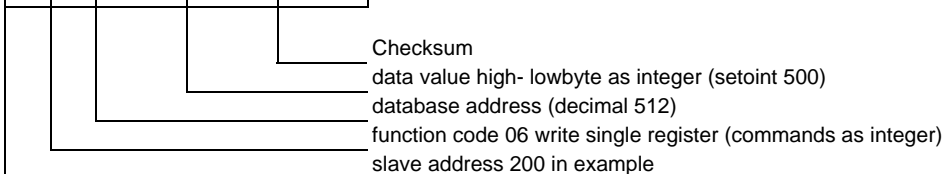

Response

C8	06	02	00	01	F4	99	FC
----	----	----	----	----	----	----	----

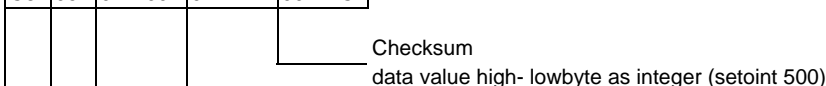

Supplement operating manual for DREHMO i-Matic actuators with integrated MODBUS fieldbus interface

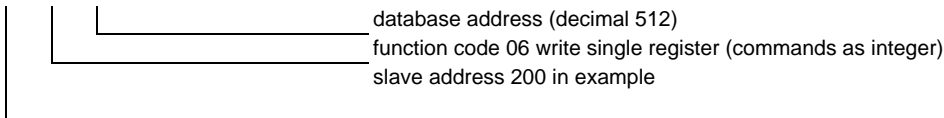

The actuator commands can also be read back for checking purposes with the function codes FC 01 (Read Coil Status) or FC 03 (Read Holding Registers). The following tables give telegram examples for these function codes.

telegram example FC01 read single bit of master output data (command check)

Request

C8	01	00	00	00	80	2C	33
----	----	----	----	----	----	----	----

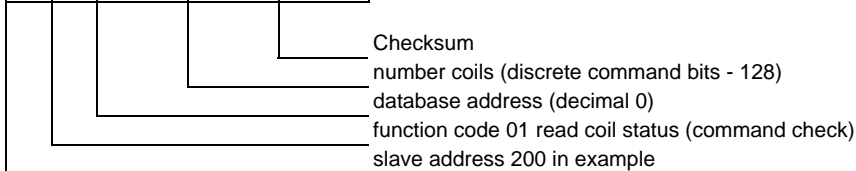

Response

C8	01	10	00	00	00	00	00	00	00	00	00	00	00	00	00	00	00	00	00	A6	6D
----	----	----	----	----	----	----	----	----	----	----	----	----	----	----	----	----	----	----	----	----	----

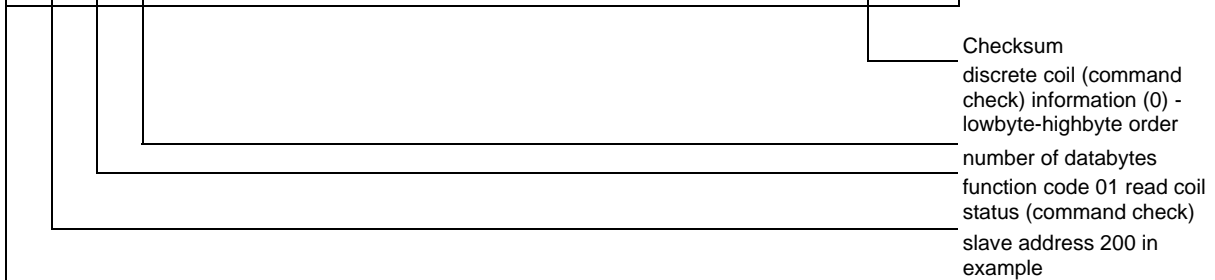

telegram example FC03 read back of master output as integer (command check)

request

C8	03	02	00	00	08	54	2D
----	----	----	----	----	----	----	----

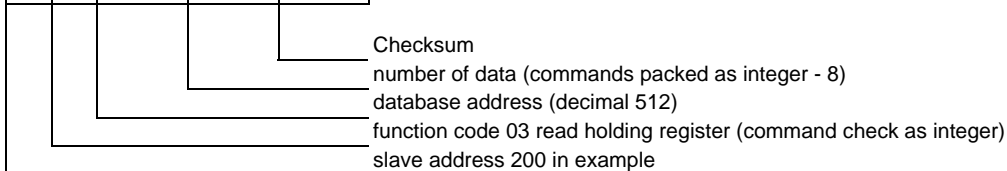

Response

C8	03	10	00	00	00	00	00	00	00	00	00	00	00	00	00	00	00	00	00	00	07	D5
----	----	----	----	----	----	----	----	----	----	----	----	----	----	----	----	----	----	----	----	----	----	----

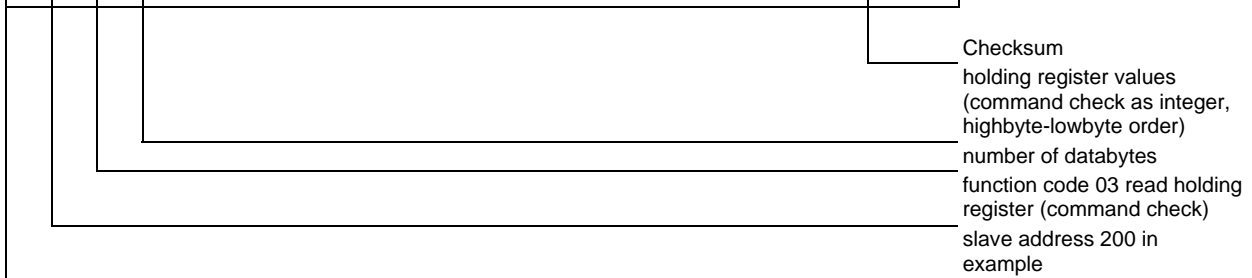

It is important to pay attention to the fact that the address count in the telegrams is starting at zero and the coil and register address counts are starting at one, thus resulting in an address offset of one!

2.4 Parameterisation

The modbus relevant settings can be changed menu driven using the local control unit. The parameters are to be found in the menu tree under Menu\Parameters\Interface\Modbus.

2.4.1 Communication settings – addresses, baud rate, parity

The slave address can be set in the range between 1 and 247. In case of redundancy, the address has to be set for both channels. The baud rate settings are done by a selection of the required and available value out of a lookup table. The parity can be set to even, odd or none. The number of stop-bits are set automatically according to the selected parity setting.

2.4.2 Number of channels – bus profile

The actuator can be ordered with a redundant modbus channel. In this case, the parameter **bus profile** is set to redundant by the manufacturer, otherwise to standard.

2.4.3 Redundancy modes – line redundant vs. master redundant

In case of a redundant interface card, it is possible to set up two different redundancy modes. The different modes have a different reply behaviour.

For line redundant mode, it is possible to block the reply of the inactive channel by setting the parameter redundancy reply to “Active channel”. This is necessary, if both channels use the same bus line with the same address setting.

In master redundant mode, the parameter has to be set to “both channels”.

For both modes, the behaviour of channel select and switch over is the same. On start-up, the actuator selects the first valid channel as active channel. If the communication on this channel fails, the actuator switches to the other channel after the timeout is expired – for description of timeout settings see description of fail-safe.

Only if none of the channels is valid, the fail-safe mechanism becomes active (if activated).

An active switchover to the other channel can be forced by setting a high to low transition on the special bit in the cyclic data stream.

2.4.4 Function Fail-Safe – Timeout setting

Once a bus communication was established, a fail-safe mode is available if the actuator is in remote mode. This fail-safe mode becomes active, if the communication is no longer active, and the set **timeout** is exhausted. The **timeout value** can be set in units of

0.1seconds in the range from 1 to 255 (0.1 to 25.5 seconds). In case of fail-safe the actuator action can be parameterised as explained in the i-Matic instruction manual.

2.4.5 Fault messages

Fault messages can be reset depending on the active fault by :

- a movement command in opposite direction in case of a torque fault
- a new movement command in case of direction monitoring
- directly if the fault is no longer existing in all other cases

2.5 Electrical connection

2.5.1 Actuators i-Matic for normal operation – DiM-X0X

2.5.1.1 Compact plug assembly

The electrical connection is done on the wiring board DiM-19 which is assembled on a mounting plate in the compact plug housing. As an example for explanation, the cable assembly for i-Matic with redundant field bus and optional two analogue and four digital process inputs as inner parts of the compact plug is given below.

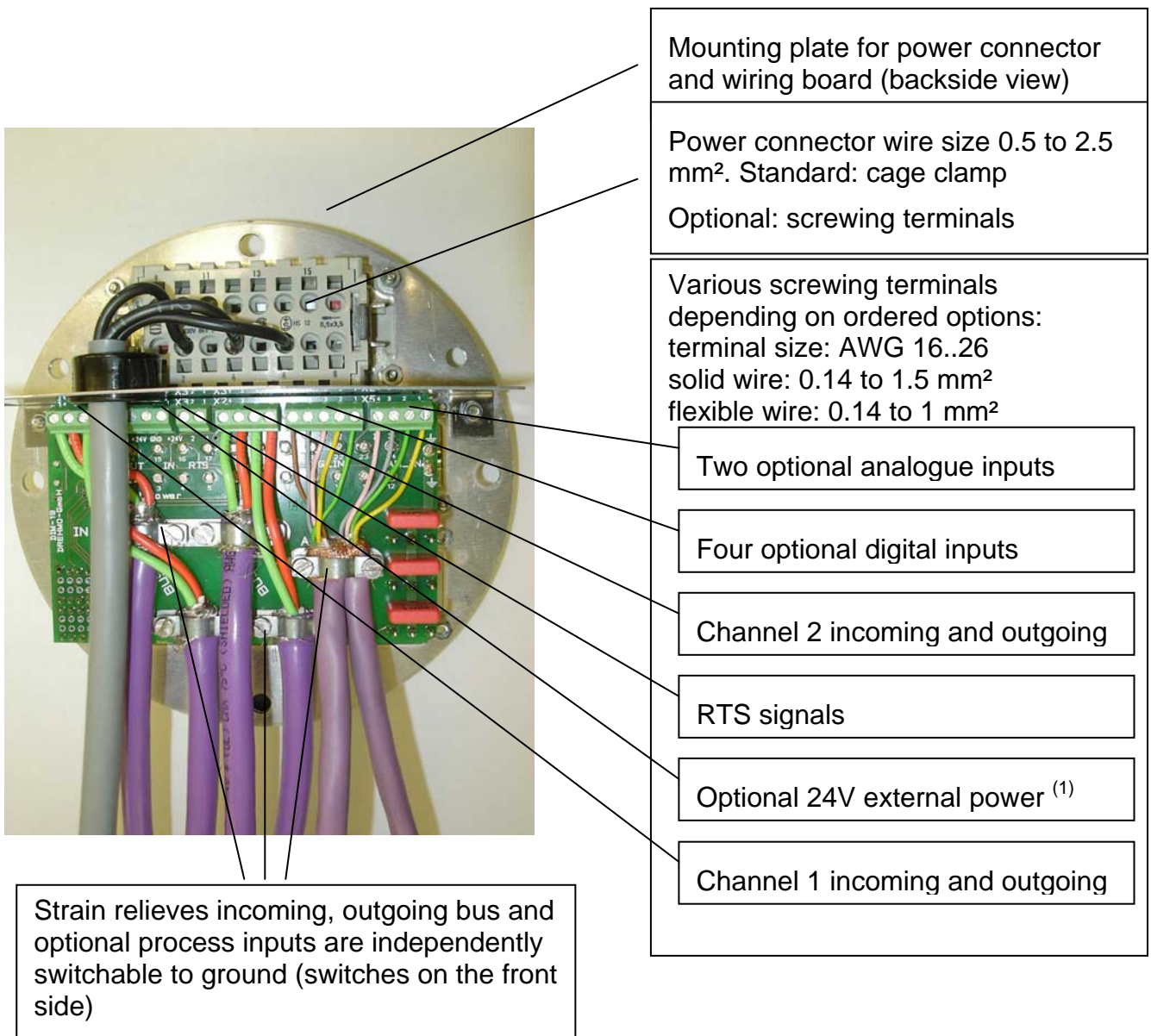

⁽¹⁾ Optional: external 24 VDC supply of i-Matic unit (input) with tolerance +10%, -5% and less than 500mA load.
Optional: auxiliary 24 VDC supply (output) for external use allows 60mA load.

**Supplement operating manual for DREHMO i-Matic actuators with integrated
MODBUS fieldbus interface**

Insight view on DREHMO i-Matic compact plug

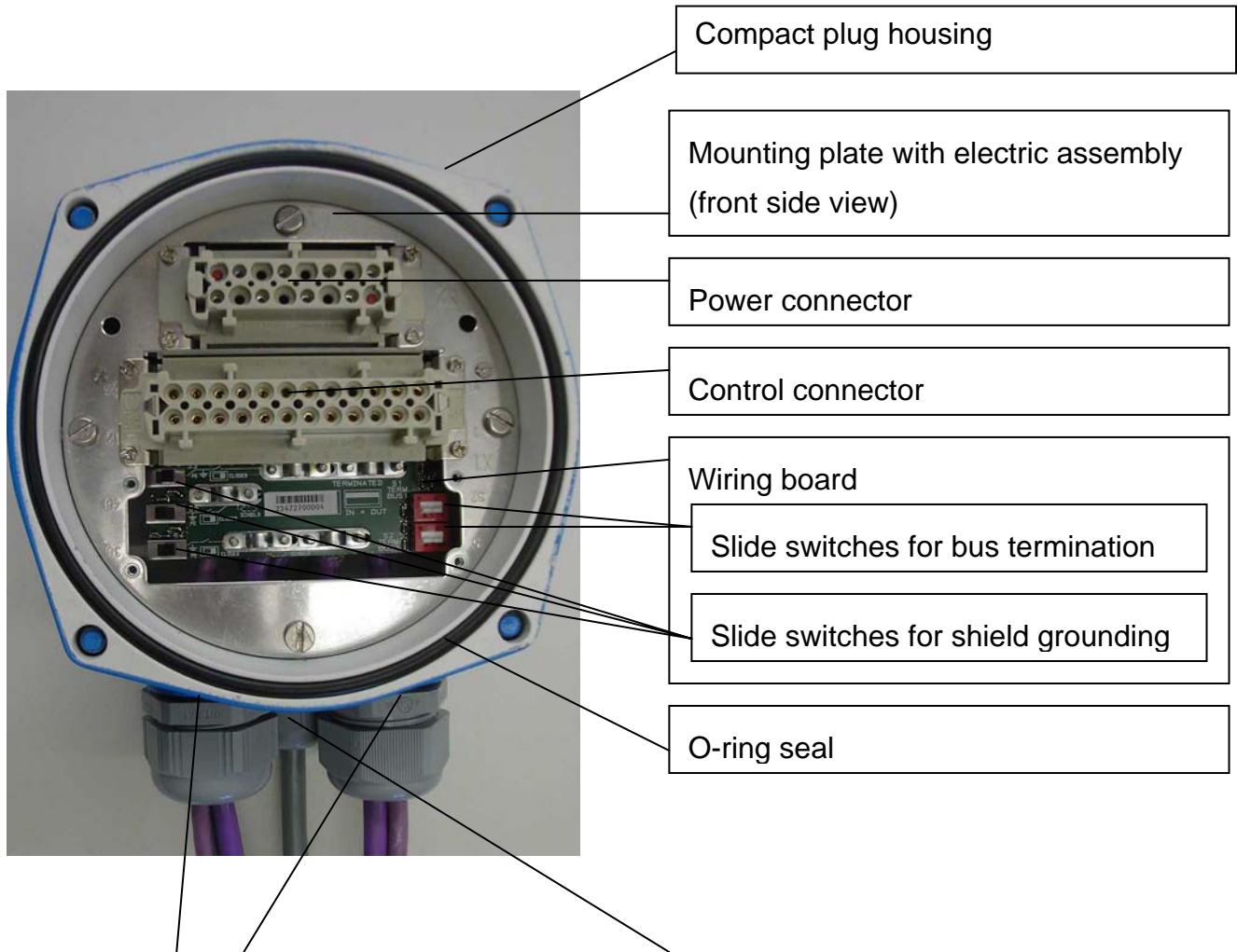

Dual cable conduits with metric (standard) winding for cable glands:
 M 32 x 1.5 mm (standard)
 PG 29 (optional)
 Device is shipped with blind plugs

Single cable conduit with metric (standard) winding for cable gland:
 M 20 x 1.5 mm (standard)
 PG 13.5 (optional)
 Device is shipped with blind plugs

The wiring of the bus lines A(-), B(+), has to be done according to the given labels on the corresponding terminals. Cables coming from the master have to be connected on the input terminals (labeled IN) and the cables going to the end of the segment have to be wired to the output terminals (labeled OUT). The connection of the shielding for incoming or outgoing cables has to be done in the same manner.

2.5.1.2 Bus termination

The termination of the bus line can be done individually for the channels 1, 2 by setting the slide switches S3, S4 on the connection board DiM-19 in the compact plug. If the termination on one of the channels is activated, the outgoing line of this channel is disconnected from the master.

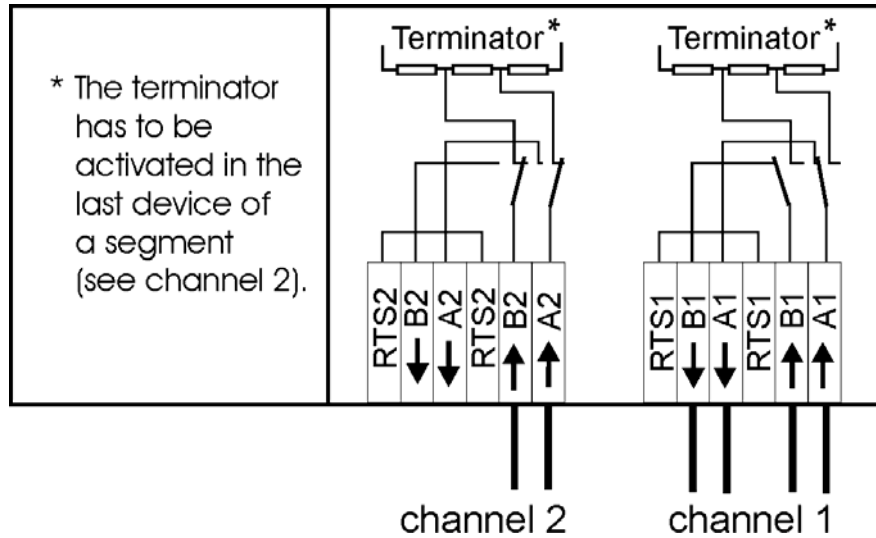

example for termination with slide switch S3, S4 on DiM-19 connection board

- channel 1 without termination – bus connection forward to next device
- channel 2 termination activated – last device on bus segment

2.5.1.3 Grounding of the cables' shields in case of copper cable use

To avoid high currents on the cables' shields in systems with very different earth potentials, the shields of the cables connected to the inputs and those connected to the outputs can be grounded directly, or using a combination of resistor and capacitor using the grounding switches (see 2.5.1.1) on the connection board. The resistor reduces DC-currents, whereas the capacitor has a low impedance for fast changes between ground potentials.

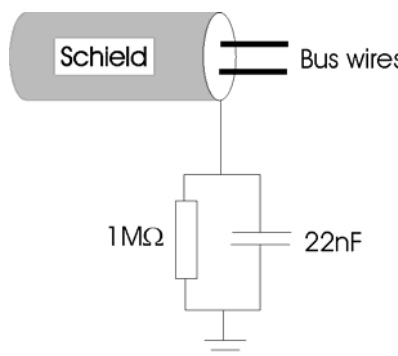

High impedance grounding of shield

Supplement operating manual for DREHMO i-Matic actuators with integrated MODBUS fieldbus interface

2.5.1.4 Interface with fibre optic connection

Actuators for ordinary surroundings (Non EX) may have an extended compact plug to incorporate a special fibre optic interface board. The connection of the fibre optic cables to the interface board is shown in the following picture:

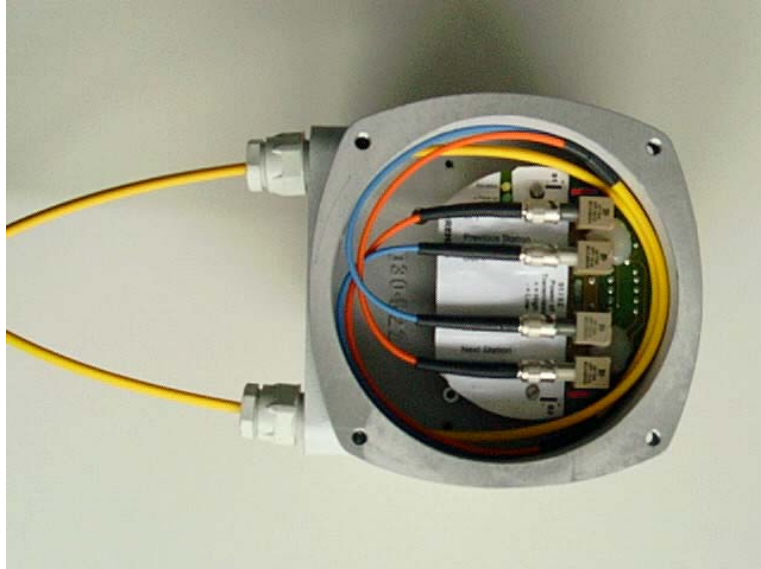

Fibre optic connection inside the compact plug

The connector for the fibre optic wires is the one of type F-St. The core of the optical fibres might be of diameter 50µm or 62.5 µm. To connect the fibre optic cables, open the cover of the extended compact plug. Using the maximum of four cable glands (M20x1.5) the cables can be inducted into the housing. Connect the optical fibres to the appropriate plugs: Connect the output of a device with the input of the other one and the input with the output. The board provides an active connection between inputs and outputs. By default the converter board is powered by the electronic unit. Thus in case of a power failure the communication to the rest of the slaves connected to the output of the device is lost. This effect can be avoided by additionally powering the electronic unit with external 24 V DC

2.5.2 Actuator i-Matic for Ex-Zone acc. ATEX device category 2 G – DiM-X1X

2.5.2.1 Connection with copper cable

The connection of the modbus signal lines (A, B) from inputs and outputs have to be done on the appropriate terminals in the termination compartment. If the actuator is not the last node on the bus, the necessary T-piece may be made up by means of using the available double terminals (A1, B1, A2, B2) which are electrically connected. A bridge between incoming and outgoing bus signals has to be made to achieve the required T-piece.

The bus terminator always has to be provided near or downstream of the last bus device for correct bus termination. If the last bus device is an i-Matic type DREHMO actuator, the terminator can be activated by connecting terminals Tx+ with Bx and Tx- with Ax (see next picture), (x = number of channel).

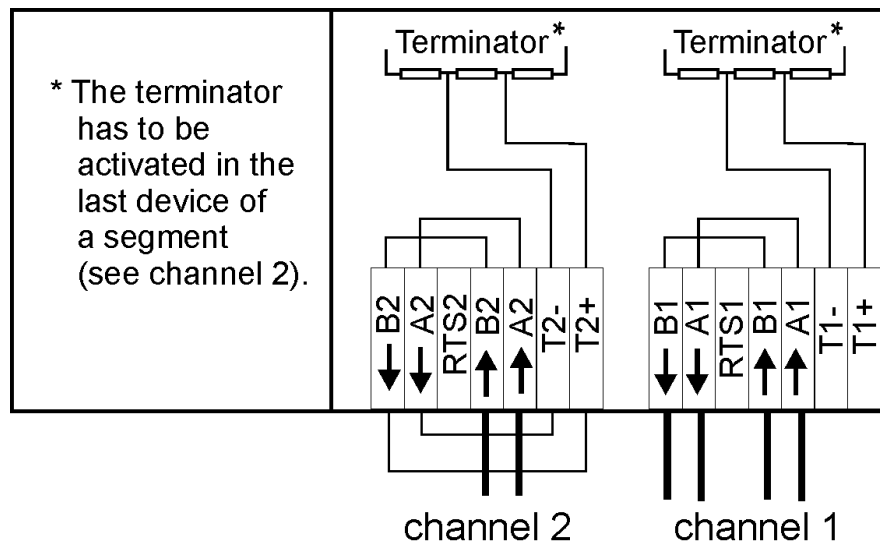

- Connection of two Profibus systems to an i-Matic drive
- channel 1: leading to the next device
- channel 2: last device on the segment (terminator activated)

Devices for use in explosive areas have a spur length of approximately 40 cm for each channel.

Supplement operating manual for DREHMO i-Matic actuators with integrated MODBUS fieldbus interface

2.5.2.2 Connection with fibre optic cable

Devices of category 2 G/D for explosive areas have the connection solely by rail mounted screw terminals. The fibre optic converter⁴⁾ inside the extended safety compartment is powered by the electronic unit. The converter is pressure proof sealed, and the optical interface is intrinsically safe. Actuators can be fitted with single line fibre optic interfaces (e.g. line or star structure), or with a redundant fibre optic interface for a ring structure. The breakout has to be put inside the compartment. It is therefore important to keep the size of the breakout small enough to be able to push it through a cable gland of the size M20. The standard connector is of type F-SMA. The following pictures show the inside of the wiring compartment.



- Connection with fibre optic interface – terminals - Connection with fibre optic interface – fibre optic cable

2.5.2.2.1 Setting of transmission power

The converter board has two switches S1 and S2. The switches can be used to set the transmission power according to the requirements of the input and output independently. If the adjacent devices are only a short distance apart, the appropriate switch should be switched to „-“ (default setting). If the transmission power is not sufficient to cover the distance between two devices, the switch can be set to position „+“.

The two LEDs on the board show whether the power supply is OK (green LED), and whether data are transferred via the optical PROFIBUS (yellow LED).

2.6 Interface to external sensor - process inputs

Actuators of type i-Matic can be equipped with an optional interface for an external sensor. The interface consists of four discrete inputs (24 V DC), and two analogue inputs (4...20mA). The discrete inputs with common ground are galvanically isolated from the electronic potential by optocouplers. The nominal current of the discrete inputs is 12 mA for an input voltage of 24 V DC. The following picture shows the structure of the discrete inputs.

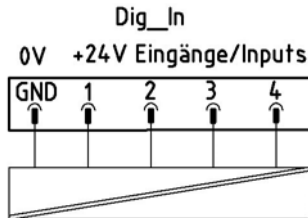

- digital process inputs

The analogue inputs are connected to the electronic potential. The following pictures show examples of how to use these inputs:

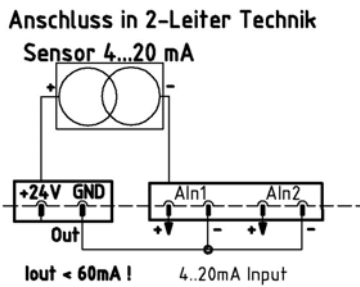

- connection with two wires

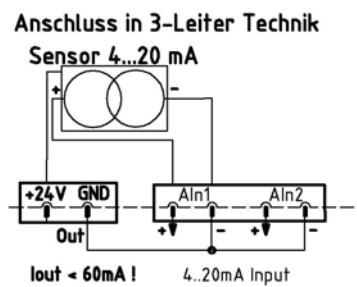

- connection with three wires

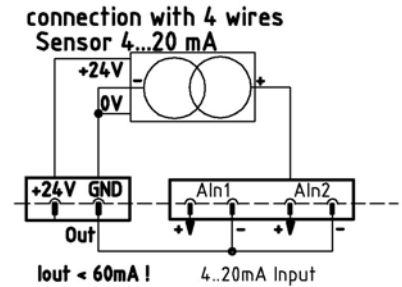

- connection with four wires

DREHMO GmbH
 Industriestraße 1
 57482 Wenden/Germany
 Fon: +49 (0) 27 62 6 12-314
 Fax: +49 (0) 27 62 6 12-476
 Internet: www.drehmo.com
 eMail: drehmo@drehmo.com