

Antriebsmaße

DREHANTRIEBE x-matic



DREHMO
VALVE ACTUATORS

Antriebsmodelle DiMEX, DiMEX R	30	59	60	120	249	250	500	1000	2000
Gewicht [kg]	23	25	33,5	33,5	33,5	69,5	80,5	90,5	190
Maße [mm]									
L max.	623	623	638	643	643	665	737	737	829
T4 max.	407	407	437	437	437	515	533	583	757
H max.	356	356	397	442	442	571	695	745	878
D1	Ø160	Ø160	Ø160	Ø250	Ø250	Ø250	Ø400	Ø500	Ø500
D2 max.	Ø127	Ø127	Ø160	Ø160	Ø160	Ø245	Ø245	Ø245	Ø245
H1a	325	325	371	371	371	492	542	542	730
H1b	322	322	340	340	340	390	390	390	449
H2	113	113	131	131	131	192	192	192	240
H4	49	49	55	55	55	69	69	69	124
H6	140	140	160	160	160	210	210	210	169
	250	250	270	270	270	452	452	452	500
	352	352	372	372	372	702	702	702	-
	452	452	472	472	472	952	952	952	-
	-	-	572	572	572	-	-	-	-
L2	238	238	244	232	232	264	311	311	348
L3	560	560	575	563	563	586	632	632	725
L5	63	63	63	80	80	80	105	105	105
T1	162	162	171	171	171	169	169	169	251
T2	299	299	308	308	308	317	317	317	390
T3	178	178	187	232	232	260	335	385	450
T4a	407	407	437	437	437	515	515	515	697

1) Elektrische Anschlussgröße „S“ als Standard. Verfügbare Optionen finden Sie auf Seite 3.

*Außenmaß wird geräteabhängig von Handrad oder Gehäuse definiert

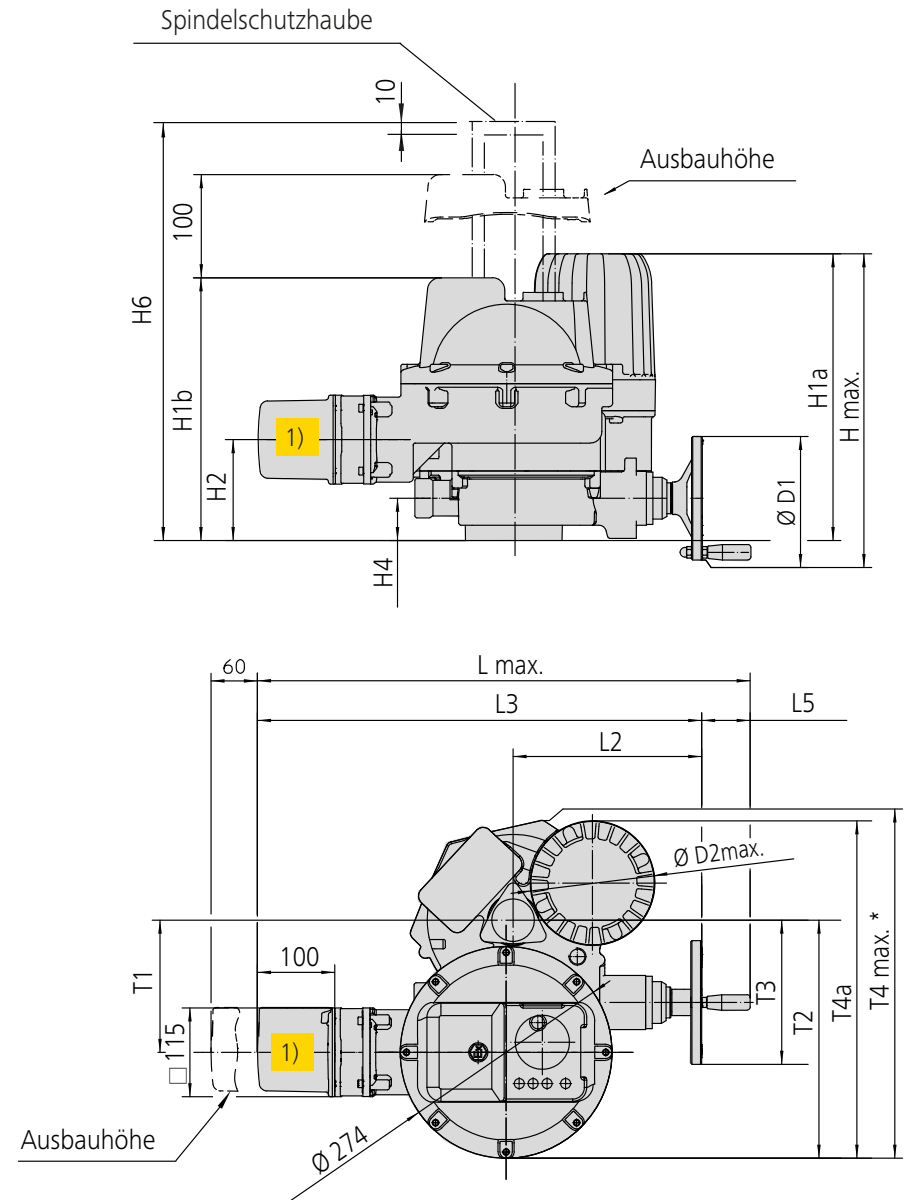

Anschlussmaße

DREHANTRIEBE x-matic

DREHMO
VALVE ACTUATORS

Antrieb DiMEx		30	59	60/120	249	250 500	1000	2000
Antrieb DiMExR		30	59	60/120		250 500	1000	
Größe DIN EN ISO 5210 DIN 3210		F07	F10	F10	F14	F14	F16	F25
		-	G0	G0	G1/2	G1/2	G3	-
Maße [mm]								
d1	FORM A	90	125	125	175	175	210	350
d _{2,18}	DIN EN ISO 5210	55	70	70	100	100	130	200
	DIN 3210	-	60	60	100	100	130	-
d ₃		70	102	102	140	140	165	254
d ₄	4 x	M8	M10	M10	M16	M16	M20	8 x M16
d ₅		26	30	40.5	40.5	52.5	65.5	85
d _{6,max}		24	28	40	40	52	65	85
h ₁		3	3	3	4	4	5	5
h ₂		12	16	16	22	23	35	24
H ₃		36	42	46	58	56	70	130
l ₁		3	3	3	5	4	5	5
l ₂		34	41	40	54	54	68.5	130

Abtriebsform A
Gewindebuchse

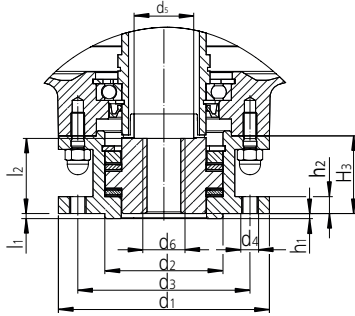

Abtriebsform B1,
B2, B
Steckbuchse *

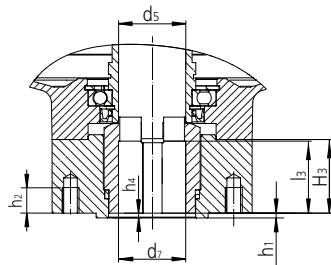
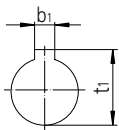

b1 ^{ISO}	FORM B1, B	8	12	12	18	18	22	28
d ₅		26	30	40.5	40.5	52.5	65.5	85
d _{7,HP}	B1, B	28	42	42	60	60	80	100
d _{7,max}	B2, B	28	42	42	60	65	80	100
H ₃		36	46	46	70	66	81	130
h ₁		3	3	3	4	4	5	5
h ₂		3	3	3	4	4	5	5
t ₁	FORM B1, B	31.3	45.3	45.3	64.4	64.4	85.5	106.4

* fehlende Maße siehe Form A

Abtriebsform
B3, B4, E
Bohrung *

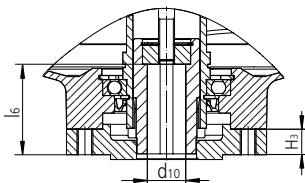
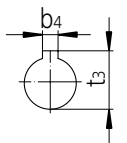

b4 ^{ISO}	FORM B3, E	5	6	6	8	8	12	14
d _{10,HP}	B3, E	16	20	20	30	30	40	50
d _{10,max}	B4, E	16	20	30	30	40	50	50
H ₃		18	17	16	22	23	28	30
l ₆		41	56	56	79	79	98	118
t ₃	FORM B3, E	18.3	22.8	22.8	33.3	33.3	43.3	53.8

* fehlende Maße siehe Form A

Abtriebsform C
Klauenkupplung *

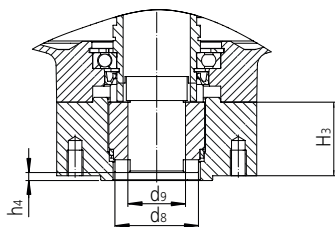
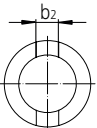

b2 ^{HP}	FORM C	14	14	14	20	20	24	30
d ₈		42	54	54	80	85	110	139.9
d ₉		26	28	28	38	38	47	85
H ₃		36	46	46	70	66	81	130
h ₄		3	3	3	4	4	5	5

* fehlende Maße siehe Form A

Abtriebsform D
Wellenende *

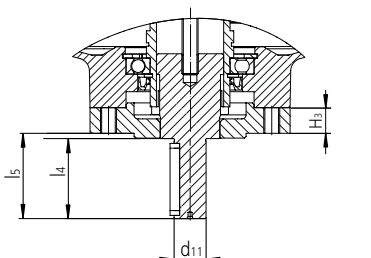
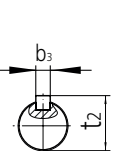

b3 _{HP}	FORM D	5	6	6	8	8	12	-
d ₁₁		16	20	20	30	30	40	-
H ₃		18	17	16	22	23	28	30
l ₄		40	50	50	70	70	90	-

Maße Elektroanschlüsse

DREHANTRIEBE x-matic

DREHMO
VALVE ACTUATORS

„KLKA“

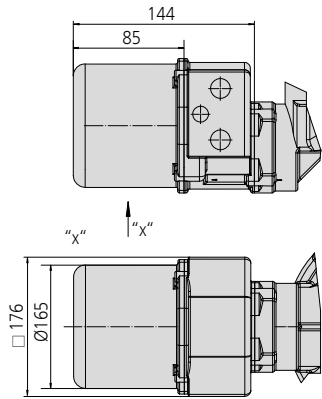

„S“

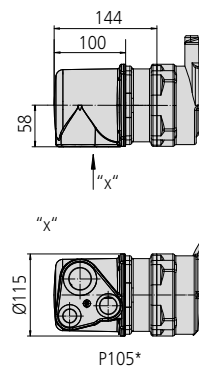

„SH“

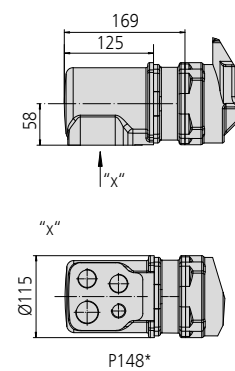

„SB“

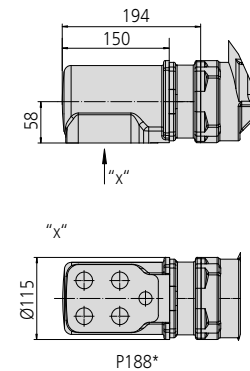

„KT Ex e“

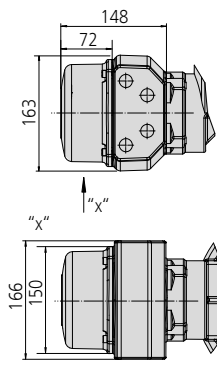
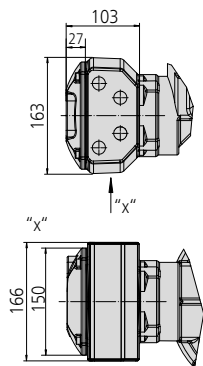

B07 P137*

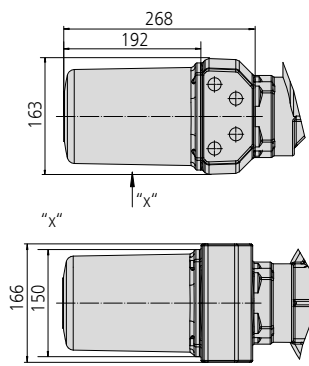

B08 P137A*

„KT Ex d“

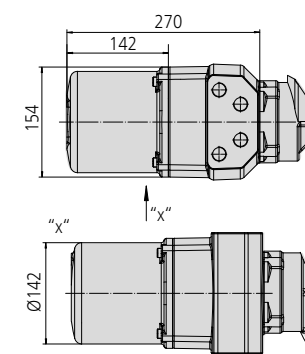
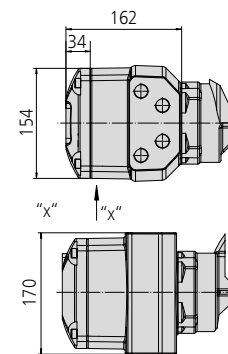

„KES Ex d“

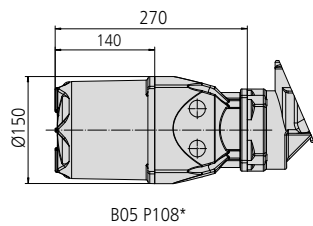

B05 P108*

„KES Ex e“

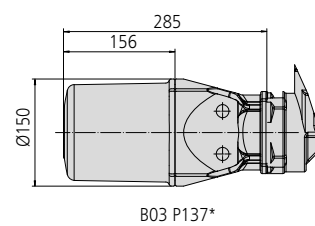

B03 P137*

* Gewindekombinationscode
Alternative Gewindekombinationscodes
optional verfügbar